

Reliability

Although the technological achievements of the last 50 years can hardly be disputed, there is one weakness in all mankind's devices. That is the possibility of failure. What person has not experienced the frustration of an automobile that fails to start or a malfunction of a household appliance. The introduction of every new device must be accompanied by provision for maintenance, repair parts, and protection against failure. This is certainly apparent to the military, where the life-cycle maintenance costs of systems far exceed the original purchase costs. The problem pervades modern society, from the homeowner who faces the annoyances of appliance failures, to electric utility companies faced with the potentially disastrous consequences of nuclear reactor failures. The insurance industry would not exist without the possibility of one type of failure or another.

A subject that is so important to many decisions in this world could hardly escape quantitative analysis. The name *reliability* is given to the field of study that attempts to assign numbers to the propensity of systems to fail. In a more restrictive sense, the term reliability is defined to be the probability that a system performs its mission successfully. Because the mission is often specified in terms of time, reliability is often defined as the probability that a system will operate satisfactorily for a given period of time. Thus reliability may be a function of time.

Estimating reliability is essentially a problem in probability modeling. A system consists of a number of components. In the simplest case, each component has two states, operating or failed. When the set of operating components and the set of failed components is specified, it is possible to discern the status of the system. The problem is to compute the probability that the system is operating -- the reliability of the system.

We use the concepts and methods of probability theory to compute the reliability of a complex system. In addition, we provide bounds on the probability of success that are often much easier to compute than the exact reliability. Although the chapter particularly relates to reliability, the methods described here are appropriate to a much larger class of problems associated with computing the probability of occurrence of complex events.

26.1 Reliability Models

A device or system is described as a collection of parts or components. The system operates successfully if all its components operate successfully (do not fail), but it may also operate if a subset of components has failed. The structure function is a model that determines the status of the system given the status of its components. We use the structure function to compute the system reliability.

The Structure Function

The *system* is a collection of n identifiable components performing some function. We define two operating states that relate to the system's ability to perform its function.

- **Success:** The system performs its function satisfactorily for a given period of time, where the criterion for success is clearly defined.

- *Failure*: The system fails to perform its function satisfactorily.

The system reliability is the probability that a system performs its function satisfactorily (i.e., the probability of success).

To provide a mathematical model of system reliability, we first consider the components. Like the system we also allow two possible states for each component. The *success indicator* for component i is the binary random variable X_i that indicates the status of component i .

$X_i = 1$ implies component i is working

$= 0$ implies component i is failed

The *status vector* is the vector of component status indicators.

$$\mathbf{X} = (X_1, X_2, \dots, X_n)$$

There are 2^n possible realizations of this vector.

The *structure function* is a binary function that indicates the status of the system (success or failure) given the status of each component.

$$\phi(X_1, X_2, \dots, X_n) \text{ or } \phi(\mathbf{X})$$

is the structure function, which has a value of 1 or 0 for each of the 2^n possible vectors \mathbf{X} . The structure function is a complete model of the failure and success characteristics of the system.

Reliability

Given the structure function of the system, one can compute its reliability. The component reliability, p_i , is the probability that component i is operating correctly. The component failure probability, q_i , is the probability that a component has failed. In terms of the success indicators,

$$p_i = P\{X_i = 1\} \text{ and } q_i = P\{X_i = 0\} = 1 - p_i.$$

When the probability of success or failure of a component does not depend on the status of some other component, the components are said to be *independent*. The assumption of this chapter is that all components are independent.

The probability that the system is operating correctly is the system reliability, R . It is the probability that the structure function is 1.

$$R = P\{\phi(\mathbf{X}) = 1\} = E[\phi(\mathbf{X})] \quad (1)$$

26.2 Simple Systems

Certain types of systems frequently arise in practice and serve to illustrate the idea of the structure function. If it is not possible to solve a problem by using the simple structures of this section, it may be possible to solve the problem by viewing it as a combination of simple structures.

Series System

A system in which all components must be operating for the system to be successful is called a *series* system. Alternatively, the failure of any one component will cause the system to fail. The word series does not imply the physical arrangement of the components; rather it describes the response of the system to the failure of one of its components. The general structure function of a series system with n components is

$$\phi(\mathbf{X}) = X_1 X_2 \cdots X_n \quad (2)$$

All of the success indicators for the components must equal 1 for the structure function to equal 1.

The reliability of a series system is the probability that all the components in the system are successful. For n independent components, this is

$$R = p_1 p_2 \cdots p_n \quad (3)$$

For example, consider a stereo system with a compact disk (CD) player, an amplifier, and two speakers (A and B). Successful operation requires all four components to work. To construct the structure function of the system we associate the indicator variables X_1 , X_2 , X_3 , and X_4 with the CD player, amplifier, speaker A, and speaker B, respectively. This is a series system, so the structure function is as follows.

$$\phi(\mathbf{X}) = X_1 X_2 X_3 X_4$$

The reliabilities of the components are: CD player ($p_1 = 0.97$), amplifier ($p_2 = 0.99$), and each speaker ($p_3 = p_4 = 0.98$). Since this is a series system, the reliability is the product of the component reliabilities:

$$R = p_1 p_2 p_3 p_4 = 0.9222.$$

Parallel System

A system for which the success of any one component is equivalent to the success of the system is a parallel system. Alternatively, all the components must fail before the parallel system fails. The structure function must have the value 1 when the indicator variable of any one component is 1 and have the value 0 only when all the indicator variables are all 0. The function that satisfies these conditions is

$$\phi(\mathbf{X}) = 1 - (1 - X_1)(1 - X_2) \cdots (1 - X_n). \quad (4)$$

The reliability of a parallel system is the probability that all of the components do not fail. Assuming independence, we have

$$R = 1 - (1 - p_1)(1 - p_2) \cdots (1 - p_n) = 1 - q_1 q_2 \cdots q_n. \quad (5)$$

Consider again the stereo system with a revised criterion for success. For successful operation the CD player, amplifier and at least one of the speakers must work. To construct the function first note that the two speakers comprise a parallel system. Then the structure function for the speaker combination is

$$\phi_s = 1 - (1 - X_3)(1 - X_4).$$

The speaker combination forms a series system with the CD player and amplifier, so the complete structure function is

$$\phi(\mathbf{X}) = X_1 X_2 \phi_s = X_1 X_2 [1 - (1 - X_3)(1 - X_4)].$$

To compute the reliability of the system, first compute the reliability of the parallel system of speakers.

$$R_s = 1 - (1 - p_3)(1 - p_4) = 1 - (0.02)(0.02) = 0.9996.$$

The speaker combination forms a series system with the CD player and amplifier, so the total reliability is

$$R = p_1 p_2 R_s = (0.97)(0.99)(0.9996) = 0.9599.$$

With the more liberal definition of success, the reliability has increased over the series system.

***k*-out-of-*n* System**

This system is successful if any k out of the n components are successful.

$$\phi(\mathbf{X}) = \begin{cases} 1, & \text{if } \sum_{i=1}^n X_i \geq k \\ 0, & \text{if } \sum_{i=1}^n X_i < k \end{cases} \quad (6)$$

This illustrates a structure function that is not a simple polynomial expression but involves a logical condition.

To compute the reliability, assume that all components have the same reliability, $p_i = p$ for all i . Then the reliability of the system is the probability that k or more components are successful. Because of the independence assumption, we can use the binomial distribution to compute the reliability.

$$R = \sum_{i=k}^n \binom{n}{i} p^i (1-p)^{n-i} \quad (7)$$

For example, a space vehicle has three identical computers operating simultaneously and solving the same problems. The outputs of the three computers are compared, and if two or three of them are identical, that result is used. This is called a majority vote system, and in this mode one of the three computers can fail without causing the system to fail. This is a two out of three system. Identifying the success or failure of each of the computers with the variables X_1 , X_2 , and X_3 , the function is written:

$$\phi(\mathbf{X}) = \begin{cases} 1, & \text{if } X_1 + X_2 + X_3 \geq 2 \\ 0, & \text{if } X_1 + X_2 + X_3 < 2 \end{cases}$$

Alternatively, the structure function written in polynomial form is

$$\phi(\mathbf{X}) = 1 - (1 - X_1X_2)(1 - X_1X_3)(1 - X_2X_3)$$

Any combination of two or more X_i set equal to 1 will cause this function to assume the value 1, while fewer than two will result in a 0 value.

With the reliability of each computer equal to 0.9, we use the binomial distribution to compute the system reliability.

$$\begin{aligned} R &= \sum_{i=2}^3 \binom{3}{i} (0.9)^i (0.1)^{3-i} \\ &= 3(0.9)^2(0.1) + (0.9)^3 = 0.972. \end{aligned}$$

The reliability of the combination of three computers is much greater than that of an individual. This is an example of the use of redundancy to increase reliability. Since only one computer is required to perform the function, the other two are redundant from a functional point of view. They do play an important role, however, in increasing the reliability of the system.

The independence of failures is important here. If some failure mechanism causes all three computers to fail simultaneously, the reliability improvement will not be realized. For example, if all three computers used the same program and the program had an error, the combination of results will certainly be no better than any one of the individual results. The use of redundancy is common in systems for which failure has particularly severe consequences, such as in the space program or for very complex systems with many components.

Reliability as a Function of Time

Often the reliability of a component is given as functions of time. For example, a common assumption is that components have an exponential distribution for time to failure. In this case the component reliability is

$$p(t) = 1 - P\{\text{failure time} \leq t\} = e^{-\lambda t}.$$

The parameter λ is called the failure rate of the component and is given in units of failures per unit time. This distribution for failure time implies that the probability that the component fails in the next small interval of time is independent of how long the component has been working. For this distribution, age is not the determinant of failure. It is often adopted for electronic components, and is also appropriate when the component itself is a complex system of many parts. After the system has been in operation for some time many of the parts will have failed and been replaced. The system becomes a mixture of old and new parts, and the failure rate approaches a constant.

One of the advantages of the constant failure rate assumption is obtained with a series system. In this case, the system reliability is

$$\begin{aligned} R(t) &= p_1 p_2 \cdots p_n = (e^{-\lambda_1 t})(e^{-\lambda_2 t}) \cdots (e^{-\lambda_n t}) \\ &= \exp - \sum_{i=1}^n \lambda_i t \end{aligned} \quad (8)$$

The system failure rate is the sum of the component failure rates.

Other failure probability distributions are appropriate for other classes of components. In common use is the Weibull distribution that models increasing failure rates with age. When component reliabilities vary with time, so must the system reliability. In such cases, we use the time varying component reliabilities, $p(t)$ in the system reliability function.

26.3 Complex Systems

If the system structure is not one of the simple forms, it becomes difficult to compute the exact reliability. To deal with the more general situation, we introduce a graphical network model in which it is possible to determine whether a system is working correctly by determining whether a successful path exists through the system. The system fails when no such path exists. We present both exact and approximate methods for computing the reliability. The methods are based on the dual concepts of minimal cuts or minimal paths of the network.

Coherent System

A system characteristic that plays an important role in the subsequent analysis is *coherency*. A coherent system has the property that when the system is successful for some status vector \mathbf{X} , it remains successful if some components of \mathbf{X} change from 0 to 1. Alternatively, if the system is failed for some status vector \mathbf{X} , it remains failed if some components of \mathbf{X} are changed from 1 to 0. More formally, a coherent system has the property that when \mathbf{X} and \mathbf{Y} are two status vectors such that $\mathbf{Y} \geq \mathbf{X}$,

$$\phi(\mathbf{Y}) \geq \phi(\mathbf{X}).$$

For a coherent system, repairing a failed component cannot cause a working system to fail. Most real systems have this characteristic including the simple systems given in the previous section.

The Network Model

We describe the system as a directed network consisting of nodes and arcs, as illustrated in Fig. 1. One node is defined as the source (node A in the figure), and a second node is defined as a sink (node D). Each component of the network is identified as an arc passing from one node to another. The arcs are numbered for identification. A failure of a component is equivalent to an arc being removed or cut from the network. The system is successful if there exists a successful path from the source to the sink. The system is failed if no such path exists. The reliability of the system is the probability that there exist one or more successful paths from the source to the sink.

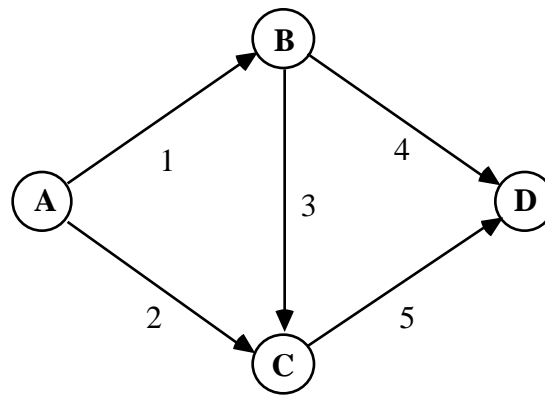

Figure 1. Network describing a system of five components

To describe the reliability of this system, we define the concepts of path, minimal path, cut, and minimal cut for the network. A path for the network is a set of components, such that if all the components in the set are successful, the system will be successful. For example, the set of all components is a path.

A minimal path is a set of components that comprise a path, but the removal of any one component will cause the resulting set to not be a path. In other words, if all the components in a minimal path are successful while all other components have failed, the system will be successful. If any one of the components in the minimal path subsequently fails, the system will fail. In terms of the network model, the minimal path corresponds to a simple path from the source to the sink in the network. In the example the sets $\{1, 4\}$, $\{1, 3, 5\}$, $\{2, 5\}$ are minimal paths. The set $\{1, 3, 4\}$ is a path, but not a minimal path. Arc 3 can be removed from the set and the set will still be a path.

A cut is a set of components such that if all the components in the cut fail, while all other components are successful, the system will fail. Again, the set of all components is a cut.

The minimal cut is a set of components that comprise a cut, but the removal of any one component from the set causes the resulting set to not be a cut. In the network a minimal cut breaks all simple paths from the source to the sink. From Fig. 1 we observe that the minimal cuts are: $\{1, 2\}$, $\{1, 5\}$, $\{2, 3, 4\}$, and $\{4, 5\}$.

Structure Function in Terms of Minimal Paths

Knowledge of the complete set of minimal cuts or minimal paths makes it possible to derive the structure function of a complex system represented by the network model. Once we have the structure function we show how to obtain exact and approximate estimates of system reliability.

We first determine the structure function in terms of the set of minimal paths. Let P be a set of components comprising a minimal path. Using X_i as an indicator of the success of component i , the event of a successful path is the binary function

$$\prod_{i \in P} X_i$$

where $\prod_{i \in P}$ means product over the set P . The event of a failed path is

$$1 - \prod_{i \in P} X_i$$

Let P_1, P_2, \dots, P_k be the collection of all minimal paths of the network. The system is successful if all the minimal paths do not fail. Then the structure function is

$$\phi_p(\mathbf{X}) = 1 - \prod_{i \in P_1} (1 - X_i) = \prod_{i \in P_2} (1 - X_i) \dots \prod_{i \in P_k} (1 - X_i) \quad (9)$$

To illustrate, the network of Fig. 1 has the minimal paths

$$\mathbf{P}_1 = \{1, 4\}, \mathbf{P}_2 = \{1, 3, 5\}, \mathbf{P}_3 = \{2, 5\}.$$

The structure function for this system from Eq. (9) is

$$\phi_p(\mathbf{X}) = 1 - (1 - X_1 X_4) (1 - X_1 X_3 X_5) (1 - X_2 X_5). \quad (10)$$

Setting the indicators of a minimal path to 1 causes the structure function to be 1. For example, setting X_1 and X_4 both to 1 makes the term on the right of Eq. (10) equal to 0. The value for the structure function, regardless of the other indicators, is then 1.

Structure Function in Terms of Minimal Cuts

The structure function can be also constructed with knowledge of the set of minimal cuts. Let C be a set of components comprising a minimal cut. The event that all components in the cut fail is

$$\prod_{i \in C} (1 - X_i)$$

The event that all the cut components do not fail is

$$1 - \prod_{i \in C} (1 - X_i)$$

Let the collection of minimal cuts for the system be C_1, C_2, \dots, C_k . The system is successful if none of the minimal cuts fail:

$$\phi_C(\mathbf{X}) = 1 - \prod_{i \in C_1} (1 - X_i) \prod_{i \in C_2} (1 - X_i) \dots \prod_{i \in C_k} (1 - X_i) \quad (11)$$

Illustrating again with the example of Fig. 1, the minimal cuts of the network are

$$C_1 = \{1, 2\}, C_2 = \{1, 5\}, C_3 = \{2, 3, 4\}, \text{ and } C_4 = \{4, 5\}.$$

Using Eq. (11) we determine the structure function

$$\begin{aligned} \phi_C(\mathbf{X}) = & [1 - (1 - X_1) (1 - X_2)] [1 - (1 - X_1) (1 - X_5)] \\ & [1 - (1 - X_2) (1 - X_3) (1 - X_4)] [1 - (1 - X_4) (1 - X_5)] \end{aligned}$$

The structure function obtained with the minimal cuts does not look very much like that obtained with the minimal paths. They do however provide the same information. It can be shown that

$$\phi_p(\mathbf{X}) = \phi_C(\mathbf{X}) \text{ for all } \mathbf{X}.$$

Computing the Exact Reliability

Starting from either of the structure functions defined above, one can multiply through the factors to obtain a sum of terms such that each term is a product of factors having the form X_i or $(1 - X_i)$. The manipulation of the formulas uses binary arithmetic which recognizes that

$$X_i X_i = X_i, \quad X_i + X_i = X_i, \quad X_i(1 - X_i) = 0, \quad X_i + (1 - X_i) = 1.$$

Manipulating Eq. (10) obtained using the minimal paths for the example, we have the following result.

$$\begin{aligned} \phi_p(\mathbf{X}) &= 1 - (1 - X_1 X_4) (1 - X_1 X_3 X_5) (1 - X_2 X_5) \\ &= X_1 X_4 + X_1 X_3 X_5 + X_2 X_5 - X_1 X_3 X_4 X_5 - X_1 X_2 X_4 X_5 \\ &\quad - X_1 X_2 X_3 X_5 + X_1 X_2 X_3 X_4 X_5 \end{aligned}$$

Once in the expanded format, we substitute p_i for X_i and q_i for $(1 - X_i)$ to obtain an exact expression for the system reliability. Substituting p_i for X_i in the preceding expression, the reliability equation for the system is

$$R = p_1 p_4 + p_1 p_3 p_5 + p_2 p_5 - p_1 p_3 p_4 p_5 - p_1 p_2 p_4 p_5 - p_1 p_2 p_3 p_5 + p_1 p_2 p_3 p_4 p_5.$$

The problem of finding the exact reliability is made difficult by the large number of minimal cuts and paths for most networks.

Examples

We illustrate the minimal cut and path approach for determining the system reliability with the simple systems of Section 26.2. More complex cases are in the exercises at the end of the chapter.

Example 1: Series System

A system has four components in series with reliabilities

$$p_1 = 0.97, \quad p_2 = 0.99, \quad p_3 = p_4 = 0.98.$$

We will find the system reliability with both the cut and path approaches.

The network for the series system is shown in the figure. The source is A and the sink is E. The component reliabilities are shown in the Fig. 2.

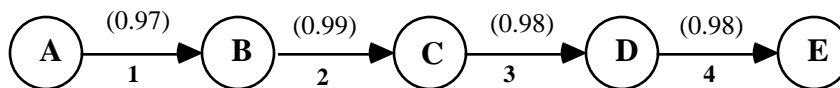

Figure 2. Network for a series system

By observation we note that the system has a single minimal path.

$$P_1 = \{1, 2, 3, 4\}$$

Using this path, the structure function can be written according to Eq. (9).

$$\phi_p(\mathbf{X}) = 1 - (1 - X_1 X_2 X_3 X_4) = X_1 X_2 X_3 X_4.$$

The reliability of the system is obtained by substituting p_i for X_i in this expression.

$$R = p_1 p_2 p_3 p_4 = 0.9222$$

Alternatively, we can derive the reliability from the cuts of the system. Again by observation we note that there are four minimal cuts.

$$C_1 = \{1\}, C_2 = \{2\}, C_3 = \{3\}, C_4 = \{4\}$$

Using Eq. (11), the system structure function is given below.

$$\begin{aligned} \phi_c(\mathbf{X}) &= [1 - (1 - X_1)][1 - (1 - X_2)] [1 - (1 - X_3)] [1 - (1 - X_4)] \\ &= X_1 X_2 X_3 X_4 \end{aligned}$$

As expected, the same structure function is obtained.

Example 2: Series - Parallel System

Now we only require that components 1, 2, and *either* component 3 or 4 must work for system success. The network for this case is shown in the Fig. 3. The network graphically illustrates that components 3 and 4 are now in parallel and the pair is in series with components 1 and 2. Node A is the source and node D is the sink.

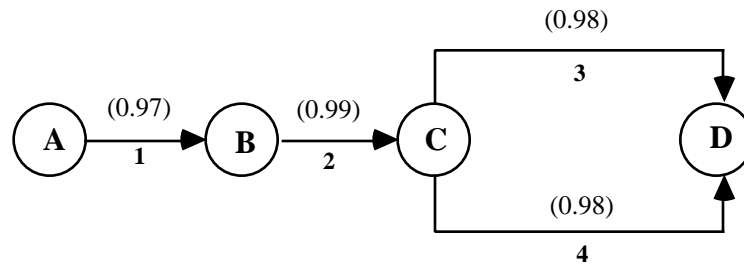

Figure 3. Network for a series-parallel system

To derive the structure function we note that the minimal paths are

$$P_1 = \{1, 2, 3\}, \text{ and } P_2 = \{1, 2, 4\}.$$

Using Eq. (9), the structure function is

$$\phi_p(\mathbf{X}) = [1 - (1 - X_1 X_2 X_3)] [1 - (1 - X_1 X_2 X_4)].$$

After the arithmetic is performed, we get

$$\phi_p(\mathbf{X}) = X_1X_2X_3 + X_1X_2X_4 - X_1X_2X_3X_4.$$

Because the structure function is now in the form of a sum of terms, the reliability is easily determined by substituting p_i for X_i .

$$\begin{aligned} R &= p_1p_2p_3 + p_1p_2p_4 - p_1p_2p_3p_4 \\ &= (0.97)(0.99)(0.98) + (0.97)(0.99)(0.98) - (0.97)(0.99)(0.98)(0.98) \\ &= 0.9599 \end{aligned}$$

which is the same as the answer obtained previously.

The results can also be found using the minimal cuts. The cuts are

$$C_1 = \{1\}, C_2 = \{2\}, C_3 = \{3,4\}.$$

Using Eq. (11),

$$\phi_C(\mathbf{X}) = [1 - (1 - X_1)] [1 - (1 - X_2)] [1 - (1 - X_3)(1 - X_4)].$$

Performing the arithmetic, we obtain

$$\begin{aligned} \phi_C(\mathbf{X}) &= 1 - (1 - X_1) - (1 - X_2) - (1 - X_3)(1 - X_4) + (1 - X_1)(1 - X_2) \\ &\quad + (1 - X_1)(1 - X_3)(1 - X_4) + (1 - X_2)(1 - X_3)(1 - X_4) \\ &\quad - (1 - X_1)(1 - X_2)(1 - X_3)(1 - X_4). \end{aligned}$$

The reliability function is obtained by replacing $(1 - X_i)$ with q_i ,

$$\begin{aligned} \phi_C(\mathbf{X}) &= 1 - q_1 - q_2 - q_3q_4 + q_1q_2 + q_1q_3q_4 + q_2q_3q_4 - q_1q_2q_3q_4 \\ &= 1 - 0.03 - 0.01 - (0.02)(0.02) + (0.03)(0.01) \\ &\quad + (0.03)(0.02)(0.02) + (0.01)(0.02)(0.02) \\ &\quad - (0.03)(0.01)(0.02)(0.02) \\ &= 1 - 0.0401 = 0.9599. \end{aligned}$$

Example 3: 2-out-of-3 System

A system has three computers of which at least two must work for successful operation. The reliability of each computer is 0.9. Find the reliability of the system.

We identify the components of the system with the indices 1, 2, and 3. This is a two out of three system. There is no way to draw a network for this system in which each component appears only once. It is possible to enumerate the minimal cuts and paths using simple logic. The minimal

requirement for system operation is that two of three computers must work, so the minimal paths are

$$P_1 = \{1, 2\}, P_2 = \{1, 3\}, \text{ and } P_3 = \{2, 3\}.$$

The minimum requirement for system failure is that two components fail, so the minimal cuts are

$$C_1 = \{1, 2\}, C_2 = \{1, 3\}, \text{ and } C_3 = \{2, 3\}.$$

In this interesting case, the sets defining the minimal cuts and the minimal paths are the same.

Using Eq. (9) we derive the structure function

$$\phi_p(\mathbf{X}) = 1 - (1 - X_1X_2)(1 - X_1X_3)(1 - X_2X_3).$$

From this expression, we obtain the structure function and the reliability.

$$\phi_p(\mathbf{X}) = X_1X_2 + X_1X_3 + X_2X_3 - 2X_1X_2X_3$$

$$R = p_1p_2 + p_1p_3 + p_2p_3 - 2p_1p_2p_3$$

When all three components have the same reliability, p ,

$$R = 3p^2 - 2p^3.$$

This expression is equivalent to the one obtained earlier for the two out of three system. A different but equivalent expression can be derived using the minimal cut approach.

Computational Considerations

This procedure can be used to derive the structure function and associated reliability function for any system for which the set of minimal paths or minimal cuts can be identified. There are two difficulties with this approach. The first is determining the set of minimal paths or cuts. In general, the system with many components will have many cuts, and it is a difficult computational problem to determine the complete set. In our examples, we have simply used observation; however, that procedure will hardly be satisfactory for a network of reasonable size. The second problem is to construct and evaluate the structure and reliability functions. In general, if there are k cuts or paths, the corresponding reliability equation will have $2^k - 1$ terms. Because of these difficulties it is common to approximate the reliability function of complicated systems. This is the subject of the next section.

For a complicated network it is often beneficial to look for subsystems of components that form simple structures such as the series, parallel, or k of n structures. The reliabilities of these subsystems can be determined first and the subsystem replaced with a single equivalent component. Even subsystems not having a simple structure can be analyzed with the methods of this section with the subsystem replaced by a single equivalent component whose reliability is the reliability of the subsystem. When as many subsystems as possible have been reduced in this fashion,

the resultant network will be much smaller and will perhaps have a simple structure or be amenable to further reduction. This decomposition approach is often effective in significantly reducing computational effort.

Complex structures will have different numbers of minimal cuts and paths. Because an exact analysis can be done using either, it is best to use the method with the smallest number. For instance, a series system with n components has n cuts but only one path. A parallel system with n components has n paths but only one cut.

26.4 Bounds on Reliability

One of the reasons why it is difficult to compute the exact reliability of a complex system concerns the difficulty in manipulating the structure function to obtain the proper form. The minimal paths and cuts defined in the previous section can be used to obtain upper and lower bounds on the exact reliability in a fashion that makes it unnecessary to do these manipulations.

Upper Bound on Reliability

This bound is obtained by computing the probability that at least one minimal path is successful with the added assumption that paths fail independently. The upper bound is

$$R_U = 1 - \prod_{i=1}^k (1 - p_i) \quad (13)$$

where P_1, P_2, \dots, P_k are the minimal paths of the network. The inaccuracy in Eq. (13) arises from the fact that, in general, paths are not independent since some components are common to more than one path.

Lower Bound on Reliability

This bound is obtained by computing the probability that every minimal cut is successful, with the added assumption that cuts fail independently. Thus the lower bound is

$$R_L = \prod_{i=1}^k (1 - q_i) \quad (14)$$

where C_1, C_2, \dots, C_k are the minimal cuts of the network. Similarly, the inaccuracy in Eq. (14) arises from the fact that, in general, cuts are not independent since some components are common to more than one cut.

Example 4

Consider the 2-out-of-3 problem with components 1, 2, and 3. The minimal paths of the system are

$$P_1 = \{1, 2\}, P_2 = \{1, 3\} \text{ and } P_3 = \{2, 3\}.$$

The minimal cuts of the system are

$$C_1 = \{1, 2\}, C_2 = \{1, 3\} \text{ and } C_3 = \{2, 3\}.$$

Using the paths with Eq. (13), we obtain

$$R_U = 1 - (1 - p_1 p_2) (1 - p_1 p_3) (1 - p_2 p_3).$$

Using the cuts with Eq. (14), we obtain

$$R_L = (1 - q_1q_2)(1 - q_1q_3)(1 - q_2q_3).$$

Assuming all components have equal reliabilities of 0.9 ($p = 0.9$, $q = 0.1$), the bounds become

$$R_U = 1 - (1 - p^2)^3 = 1 - (0.19)^3 = 0.9931$$

$$R_L = (1 - q^2)^3 = (0.99)^3 = 0.9703.$$

This compares to the exact reliability calculated earlier, $R = 0.972$.

Modeling

In the preceding example, the lower bound appears to be closer to the exact reliability than the upper bound. The lower bound will usually be a better approximation when component reliabilities are high (> 0.9). With high component reliabilities it is more likely that a single cut will cause failure rather than a collection of two or more. The assumption of independence of cuts will cause less inaccuracy in this case. The cut approximation converges to the true reliability as the component reliability approaches 1. The upper bound approximation will usually be a better approximation when the component reliability is very low. In most studies, component reliabilities are high implying that a lower bound is a conservative measure of reliability. Therefore, from a practical point of view, the minimal cut approximation is the more important of the two.

26.5 Exercises

1. A missile complex has four subsystems: the radars, the missile, the computer control devices, and the human operators. Four radars are provided, of which three are required for successful operation. The complex has only a single missile. There are three computers operating in a majority vote arrangement. There are two human operators, one of whom must be capable of firing the missile. Write the structure function for this system consisting of 10 components.
2. A student drives to school each day over the same route. She prides herself on her ability to control the speed of her car so she never has to stop at a traffic signal. She calls her trip successful if she can accomplish that feat. If there are six traffic signals on his route, show the structure function for the system of traffic signals for this particular driver. How would the structure function change if the student were willing to change her criterion of success to allow a pause at no more than one signal?
3. To increase the likelihood that a vaccine for a disease will be discovered, the government awards independent study contracts to four drug firms. Surely, they say, one of the companies will make the discovery. If success is defined as the discovery of the vaccine, what is the structure function for this system?
4. Compute the reliability of the system described in Exercise 1 when the reliabilities of the various components are given in the following table.

Component	Radar	Missile	Computer	Human
Reliability	0.9	0.96	0.98	0.95

5. The Defense Department would like to increase the reliability of the missile system described in Exercise 4. Evaluate the system reliabilities for the changes proposed below. The changes are not cumulative.
 - a. Add another radar with the same reliability. Three radars are required for successful operation.
 - b. Add a third human operator. Only one is required.
 - c. Add an entire duplicate missile system at a nearby location. Only one of the two systems must work for mission success.
6. Three computers are operated in parallel with a majority vote taken of their outputs to determine the proper action. Find the reliability of the system as a function of time. Assume the time for failure of each of the computers has an exponential distribution with a mean time between failures of 50 hours. The failure rate (λ) is the reciprocal of the mean time between failures. Plot a curve of the reliability as a function of time over the range 0 to 100 hours. Plot the curves for the system and for a single computer. Comment on the effects of this arrangement of redundancy over time.
7. Assume that all three computers in Exercise 6 must be in working order for system success. With the failure rates used in Exercise 6, plot system reliability over the range in time of 0 to 100 hours. What is the failure rate of the system?

8. Assume that the three computers in Exercise 6 are arranged in parallel and that only one must be working for system success. With the failure rates used in Exercise 6, plot system reliability over the range in time of 0 to 100 hours.
9. The figure below represents a series-parallel system. The components in each parallel set all have the same reliability as shown on the figure.

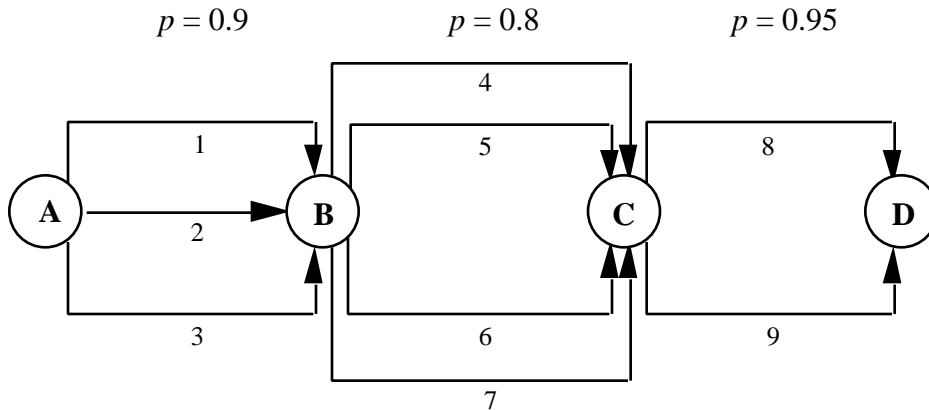

Find the system reliability as instructed.

- Construct the reliability function by enumerating the minimal paths.
 - Construct the reliability function by enumerating the minimal cuts.
 - First evaluate the parallel structures and then combine the results to form a series system.
10. Find the system reliability for the flow network with both the cut and path methods.

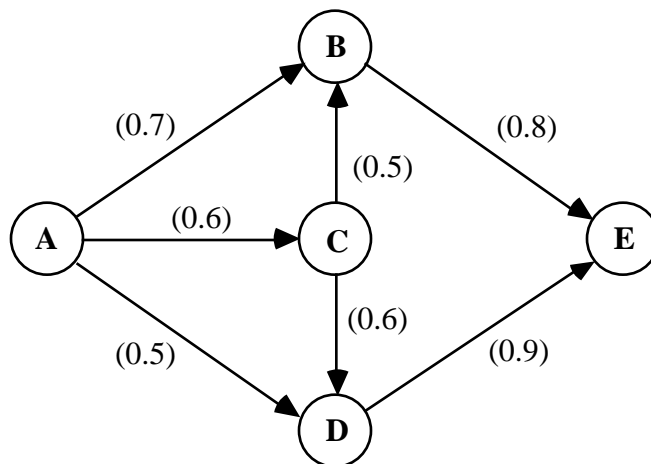

- Compute the upper and lower bound approximations for the network in Exercise 9 and compare them with the exact reliability.
- Compute the upper and lower bound approximations for the network in Exercise 10 and compare them with the exact reliability.

13. For the 2-out-of-3 system considered in Example 3, compute the upper and lower bound approximations as a function of time. Assume each component has an exponential distribution for time to failure with a failure rate of 0.02/hour. Plot a curve showing the upper and lower bound approximations together with the exact reliability curve over the time range from 0 to 100 hours.
14. Repeat Exercise 13 if the system is a 1-out-of-3 system.
15. Repeat Exercise 12 if the system is a 3-out-of-3 system.
16. The figure shows a system with nine components and corresponding reliabilities. Components 3, 4, and 5 form a 2-out-of-3 system. Write the structure function for this system. Compute the exact probability that a successful path will exist from A to B. Compute the minimal cut and minimal path approximations.

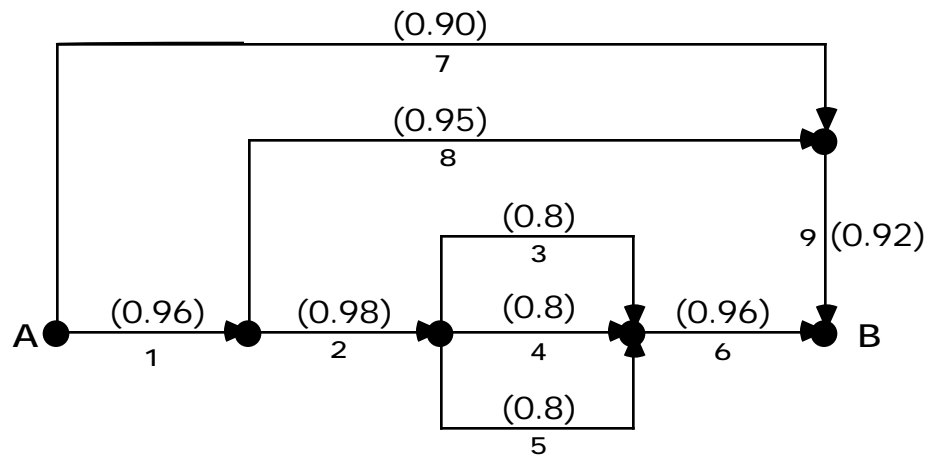

17. A fuse is used to protect an electrical circuit from overload. The fuse can fail in two modes, short and open. If it fails in the short mode, the fuse will not interrupt the circuit when it is activated. If it fails in the open mode, the circuit will be interrupted by the fuse itself. Assume a single fuse has probabilities of open and short of q_o and q_s , respectively. The events of open and short are mutually exclusive. Define success in two ways: the system does not fail because of shorts, and the system does not fail because of opens.

For the given arrangements shown in the figure, write structure functions for both definitions. Let the reliability be the probability that the system does not fail in either mode. Compute accurate reliabilities for each definition for success using $q_o = 0.05$ and $q_s = 0.1$.

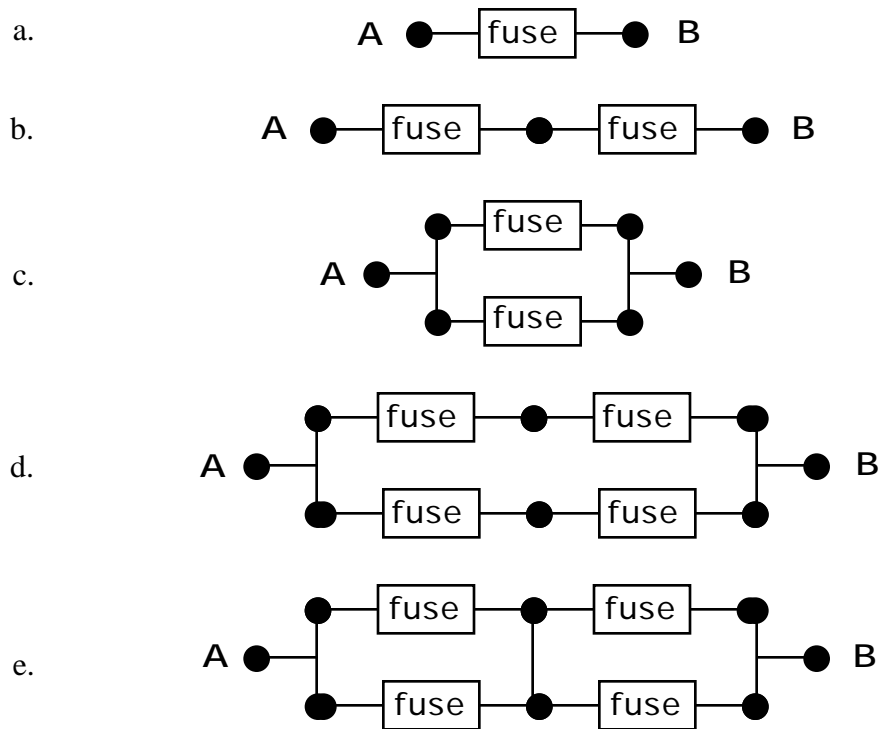

18. The figure shows roads between two towns, A and B, in a mountainous area. During the winter, travel is difficult because of the threat of snow. The probability that any given road will be impassable is 0.6. The conditions on the roads are independent. Find the probability that there will be a passable route from A to B. Roads can be traveled in either direction. Find the accurate probability and also the minimal cut and minimal path approximations.

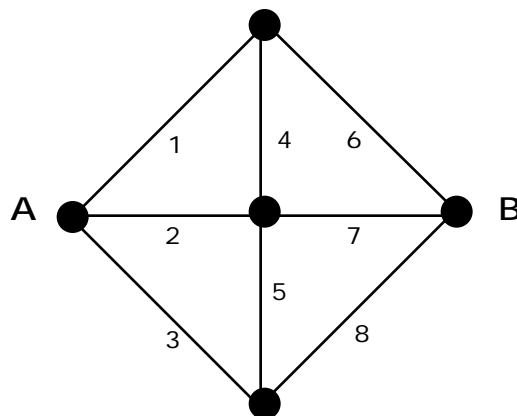

19. The figure shows the pipe layout in a lawn sprinkler system. Sprayers are located at every intersection of the pipe and also at the corners of the system. Thus there are 16 sprayers. Two things can happen to a sprayer -- it can break off or it can get clogged. If any one of the sprayers breaks off, a great stream of water will pour forth and the system will have failed. If one of the sprayers clogs, it will fail to water the lawn in the immediate vicinity; however, adjacent sprayers can reach the affected areas. The

system is judged to be failed if any two adjacent sprayers are both failed. For one sprayer, let the probability of breakage be 0.01 and the probability of clogging be 0.05. Find the reliability of the system (the probability that it does not fail in either mode) using the minimal cut approximation.

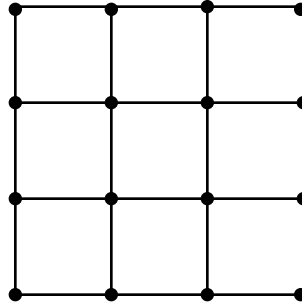

Bibliography

Ansell, J.I. and M.J. Phillips, *Practical Methods for Reliability Data Analysis*, Oxford University Press, New York, 1994.

Gnedenko, B., I. Pavlov, I. Ushakov, (edited by S. Chakravarty), *Statistical Reliability Engineering*, John Wiley & Sons, New York, 1999.

Hoyland, A. and M. Rausand, *System Reliability: Models and Statistical Methods*, John Wiley & Sons, New York, 1994.

Leemis, L.M, *Reliability: Probabilistic Models and Statistical Methods*, Prentice-Hall, Englewood Cliffs, NJ, 1995.

Leitch, R.D., *Reliability Analysis for Engineers: An Introduction*, Oxford University Press, New York, 1995.

Meeker, W.Q. and L.A. Escobar, *Statistical Methods for Reliability Data*, John Wiley & Sons, New York, 1998.